

exo267CU3

EXO USB3 Vision



The SVCam EXO is one of the most flexible and scalable cameras for the industrial market segment. The USB3 Vision interface is easy to integrate in your system, with a data rate up to effective 360 MB/sec. The time to market for applications is shortened, saving cost even further. Power the camera via the interface and reduce cable complexity.

Technical Highlights

- > Up to 360 MB/s effective transfer rate
- > Leverages existing infrastructure for cables and connectors
- > Powers camera with up to 4.5 W
- > GenICam compliant
- > Cost effective / Easy implementation and interfacing

EXO Series

exo267CU3

Resolution [MP]	8.8 MP
Resolution (h x v)	4096 x 2160 px
Frame rate (max.)	32 fps
Chroma	color
Interface	USB3 Vision
Sensor	
Sensor	IMX267LQR
Manufacturer	Sony
Sensor type	Area CMOS
Shutter type	global shutter
Sensor size (h x v)	14.13 x 7.45 mm
Optical diagonal	15.98 mm
Sensor format	1"
Pixel size (h x v)	3.45 x 3.45 μm
Camera	
Exposure modes	MANUAL;AUTO;EXTERNAL
Trigger modes	INTERNAL;SOFTWARE;EXTERNAL
Exposure time (min)	29 μs
Exposure time (max)	1 sec (external ∞)
Pixel format / max	bayer8, bayer12packed / 12 bit
Gain modes / max	manual, auto / 48 dB
S/N ratio (max)	39 dB (dep. on environment)
Dynamic range (max)	72 dB (dep. on environment)
Internal memory	256 MB SDRAM, 32 MB Flash
Feature Set	
Manual white balance	yes
Automatic white balance	yes
AOI	yes
LUT	yes
Offset	yes
Binning	yes
Image flip	yes
Shading correction	yes
Defect pixel correction	yes
Sequencer	yes
Housing	
Lens mount	C-Mount
Dimensions (w x h x d)	50 x 50 x 43 mm
Weight	138 g
Operating temperature (housing)	-10 to 60 °C
Ambient humidity	10 to 90 % (non-condensing)
Protection class	IP40
I/O-Interfaces	
Input up to 24V	2 x
Input OPTO	1 x

Dimensions [mm]

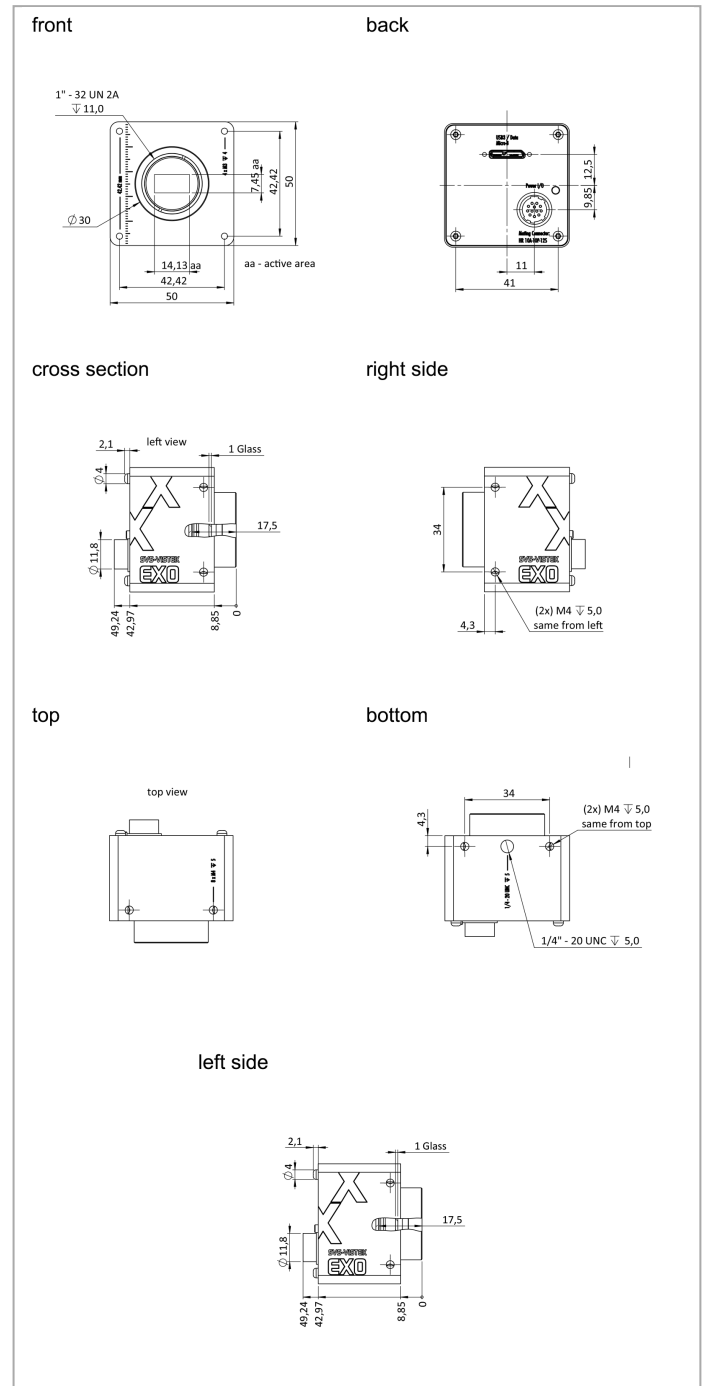

Pinout Mating Connector

Hirose 12 Pin	1	VIN - (GND)	7	OUT 1 (open drain)
	2	VIN + (10 V to 25 V DC)	8	OUT 2 (open drain)
	3	IN 4 (RXD RS232)	9	IN 3 + (opto In +)
	4	OUT 4 (TXD RS232)	10	IN 3 - (opto In -)
	5	IN 1 (0-24V)	11	OUT 3 (open drain)
	6	IN 2 (0-24V)	12	OUT 0 (open drain)

Spectral Response *

Output open drain	4 x
I/O RS-232	1 x
Power supply	10 to 25 V (DC)
Power consumption	4.5 W (dep. on operating mode)

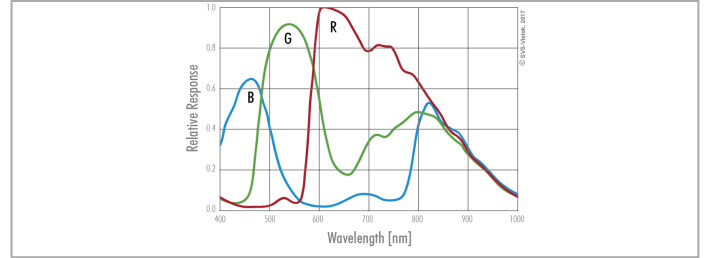

* Sensor data – excludes camera cover- or IR-cut filter characteristics