

exo267CGE

EXO GigE



Form follows requirements

With uniform size and standard interfaces comes simple interchangeability, allowing the system integrator to easily adapt a solution to varying conditions and requirements - with minimal design effort. SVS-Vistek meets precisely these needs. The EXO series is a perfect match with its uniform form factor and feature set, combined with industry standard interfaces. A solution for virtually every case, allowing smooth and effortless up- or downscaling. Once designed in, the implementations can be varied endlessly.

SVCam EXO series cameras with GigE Vision interface give your applications an extreme scalability. Quick and easy hardware interchangeability results in shorter design cycles and reduced development costs. Further value is added to your application by a virtually limitless feature set. As an example, the 4I/O LED driver with standardized software control.

Technical Highlights

- > IO interface with 2xIN, 4xOUT, Opto and RS232
- > integrated 4-channel power strobe controller for direct LED control
- > SafeTrigger, programmable timers, logic functions (PLC) and sequencer
- > progressive scan/global shutter sensors
- > POE (Power Over Ethernet) single-cable option
- > Burst mode, ROI, binning, lookup tables
- > SDK for Windows (32/64 bit), Linux
- > GenICam standard with GenTL driver
- > up to 120 MB/s data rate, up to 100m cable length
- > broadcast-safe

SVS-Vistek GmbH - Ferdinand-Porsche-Str. 3 - 82205 Gilching - Germany - Telephone +49 8105 3987-60

Information accurate as to: 07.07.2022, errors and omissions excepted.

© 2022 – SVS-Vistek GmbH, all rights reserved.

EXO Series

exo267CGE

Resolution [MP]	8.8 MP
Resolution (h x v)	4096 x 2160 px
Frame rate (max.)	13.5 fps
Frame rate burst mode (max.)	20 fps
Chroma	color
Interface	GigE Vision

Sensor

Sensor	IMX267LQR
Manufacturer	Sony
Sensor type	Area CMOS
Shutter type	global shutter
Sensor size (h x v)	14.13 x 7.45 mm
Optical diagonal	15.98 mm
Sensor format	1 "
Pixel size (h x v)	3.45 x 3.45 μm

Camera

Exposure modes	MANUAL;AUTO;EXTERNAL
Trigger modes	INTERNAL;SOFTWARE;EXTERNAL
Exposure time (min)	29 μs
Exposure time (max)	1 sec (external ∞)
Pixel format / max	bayer8, bayer12packed / 12 bit
Gain modes / max	manual, auto / 48 dB
S/N ratio (max)	39 dB (dep. on environment)
Dynamic range (max)	72 dB (dep. on environment)
Internal memory	256 MB SDRAM, 32 MB Flash

Feature Set

Manual white balance	yes
Automatic white balance	yes
AOI	yes
LUT	yes
Offset	yes
Readout control	yes
Binning	yes
Image flip	yes
Shading correction	yes
Defect pixel correction	yes
Sequencer	yes
POE	yes
PTP	yes
Color Transformation Control	yes

Housing

Lens mount	C-Mount
Dimensions (w x h x d)	50 x 50 x 43 mm
Weight	140 g
Operating temperature (housing)	-10 to 60 °C

Dimensions [mm]

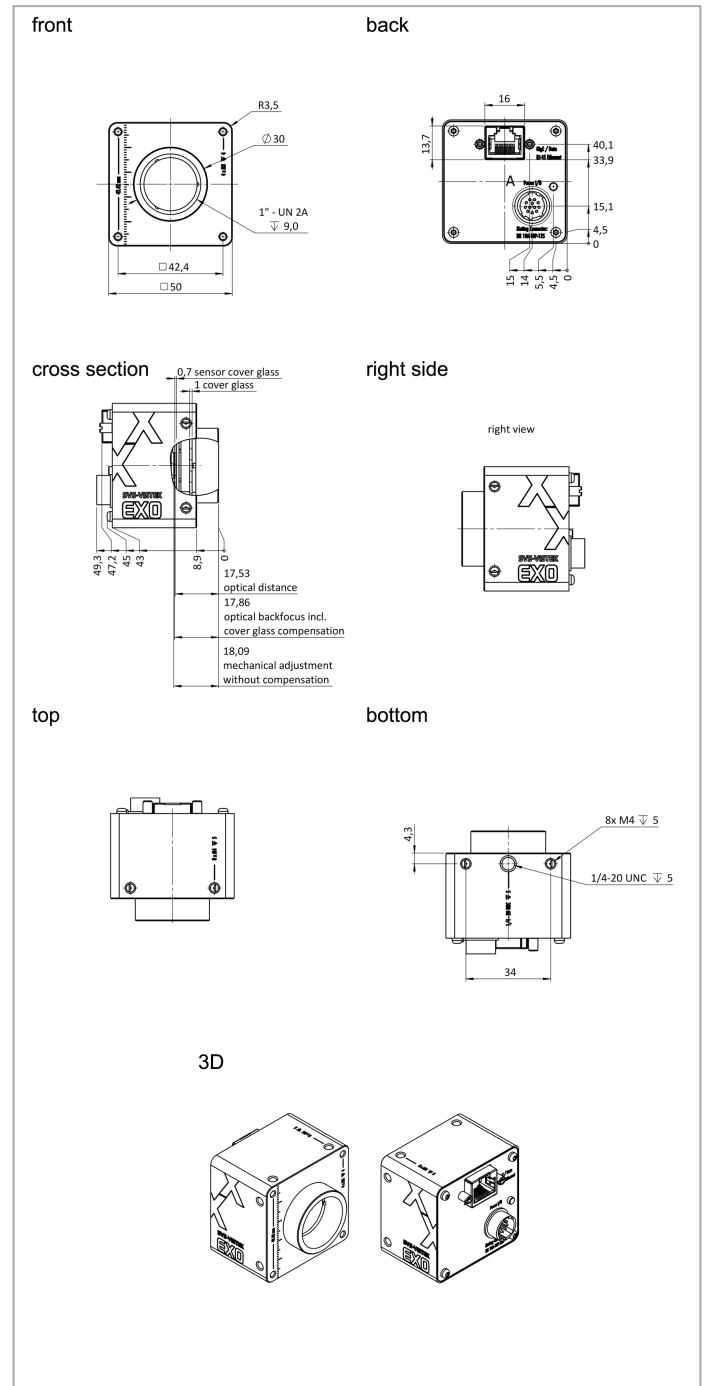

Pinout Mating Connector

Hirose 12 Pin	1	2	3	4	5	6	7	8	9	10	11	12
	VIN - (GND)	VIN + (10 V to 25 V DC)	IN 4 (RXD RS232)	OUT 4 (TXD RS232)	IN 1 (0-24V)	IN 2 (0-24V)	OUT 1 (open drain)	OUT 2 (open drain)	IN 3 + (opto In +)	IN 3 - (opto In -)	OUT 3 (open drain)	OUT 0 (open drain)

Spectral Response *

Ambient humidity	10 to 90 % (non-condensing)
Protection class	IP40
I/O-Interfaces	
Input up to 24V	2 x
Input OPTO	1 x
Output open drain	4 x
I/O RS-232	1 x
Power supply	10 to 25 V (DC)
Power consumption	4.5 W (dep. on operating mode)

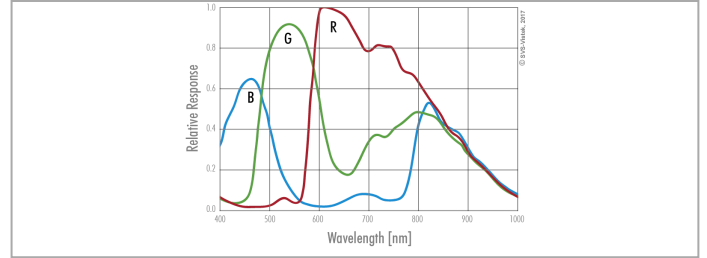

* Sensor data – excludes camera cover- or IR-cut filter characteristics