

4

3

2

1

B

B

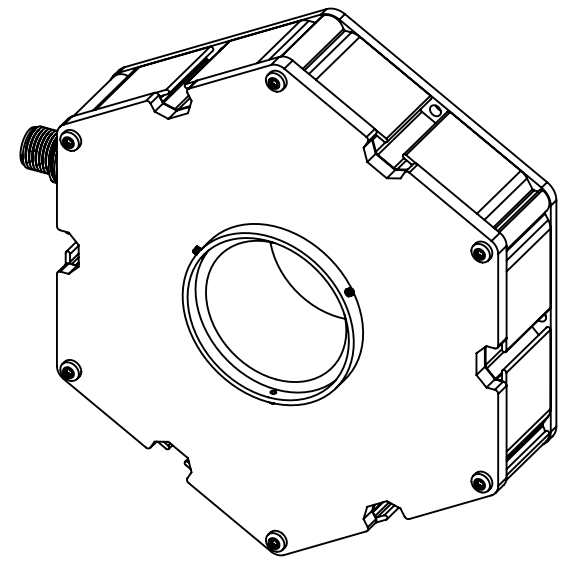
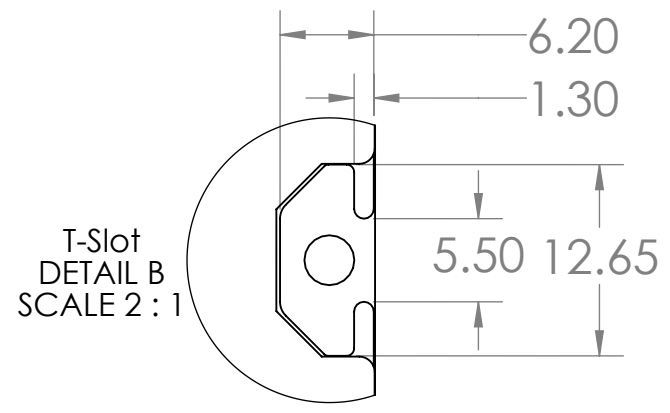

6X ϕ 3.30 THRU
M4X0.7 - 6H THRU

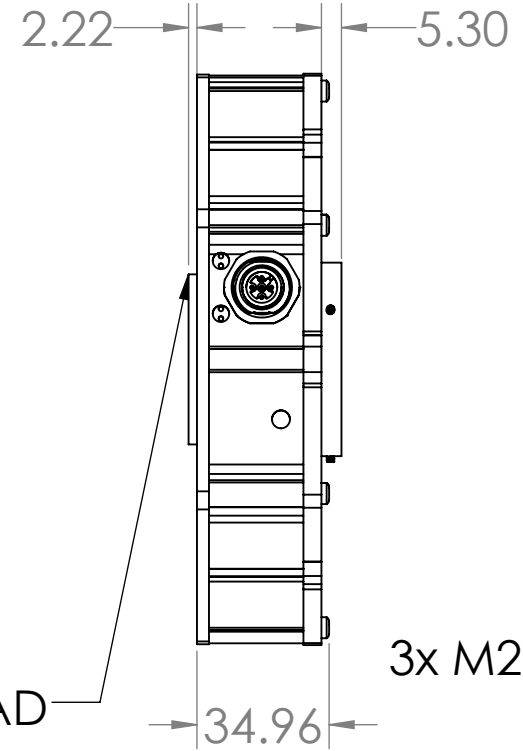
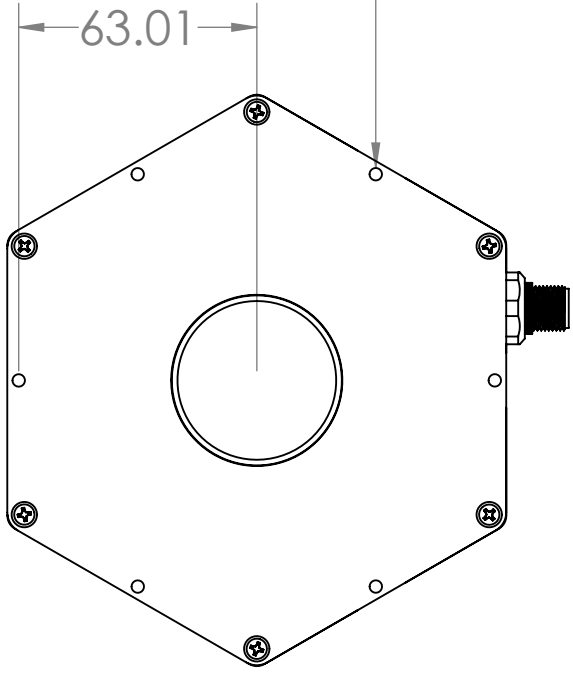

3x M2 SET SCREW

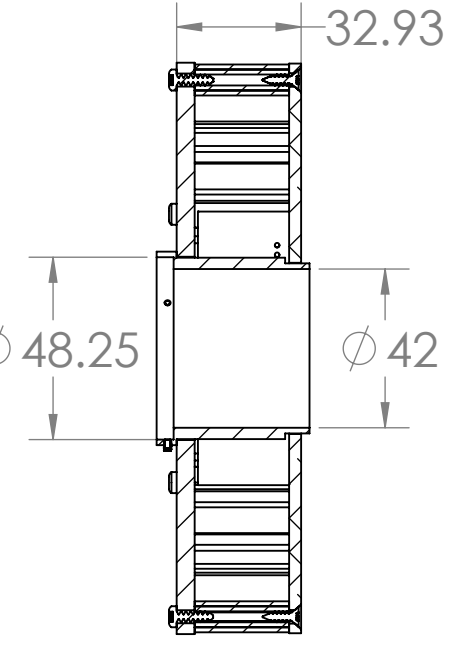
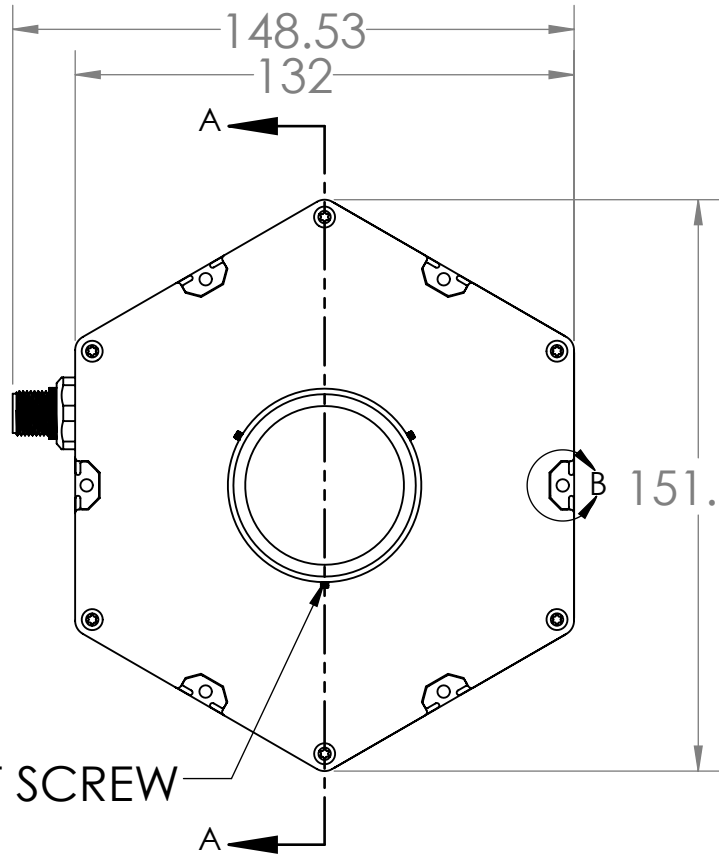

A

A

UNLESS OTHERWISE SPECIFIED:		NAME	DATE
DIMENSIONS ARE IN MM		DRAWN	LS 07/16/2019
TOLERANCES:		CHECKED	MP 07/16/2019
FRACTIONAL \pm		ENG APPR.	MP 07/16/2019
ANGULAR: MACH \pm BEND \pm		MFG APPR.	MP 07/16/2019
TWO PLACE DECIMAL \pm		Q.A.	
THREE PLACE DECIMAL \pm		COMMENTS:	
INTERPRET GEOMETRIC TOLERANCING PER:		UNITS ARE IN MILLIMETERS	
MATERIAL			
FINISH			
DO NOT SCALE DRAWING			

PROPRIETARY AND CONFIDENTIAL
THE INFORMATION CONTAINED IN THIS DRAWING IS THE SOLE PROPERTY OF SmartVisionLights. ANY REPRODUCTION IN PART OR AS A WHOLE WITHOUT THE WRITTEN PERMISSION OF SmartVisionLights IS PROHIBITED.



TITLE:
SmartVisionLights.com

SIZE	DWG. NO.	REV
B	R130	1
SCALE: 1:2		WEIGHT:
		SHEET 1 OF 1

4

3

2

1