

# Prosilica GT

## 2450



- Versatile temperature range for extreme environments
- IEEE 1588 PTP
- PoE
- P-Iris and DC-Iris lens control

## Description

### 5 Megapixel CCD camera for outdoor imaging

Prosilica GT2450/GT2450C is a 5 Megapixel camera with a GigE Vision Gigabit Ethernet interface. This camera incorporates the high quality Sony ICX625 CCD sensor with Super HAD technology providing excellent monochrome and color image quality. It is a rugged camera designed to operate in extreme environments and fluctuating lighting conditions. This camera offers Precise iris lens control allowing users to fix the aperture size to optimize depth of field, exposure and gain without the need for additional control elements.#

#### Options:

- Various optical filters and lens mounts

See the#[Modular Concept](#)#for lens mount and optical filter options.

## Specifications

Prosilica GT	2450
Interface	IEEE 802.3 1000BASE-T, IEEE 802.3af (PoE)
Resolution	2448 (H) × 2050 (V)
Sensor	Sony ICX625
Sensor type	CCD Progressive
Cell size	3.45 μm x 3.45 μm
Lens mount	C-Mount
Max frame rate at full resolution	15 fps
ADC	14 bit
Image buffer (RAM)	128 MByte
<b>Output</b>	

<b>Prosilica GT</b>	<b>2450</b>
Bit depth	14 (monochrome); 12 (color) bit
Mono modes	Mono8, Mono12, Mono12Packed, Mono14
Color modes YUV	YUV411Packed, YUV422Packed, YUV444Packed
Color modes RGB	RGB8Packed, BGR8Packed
Raw modes	BayerRG8, BayerRG12, BayerRG12Packed
<b>General purpose inputs/outputs (GPIOs)</b>	
TTL I/Os	1 input, 2 outputs
Opto-isolated I/Os	1 input, 2 outputs
RS-232	1
<b>Operating conditions/dimensions</b>	
Operating temperature	-20 °C to +65 °C ambient (without condensation)
Power requirements (DC)	7 to 25 VDC; PoE
Power consumption (@12 V)	3.8 W @ 12 VDC; 4.7 W PoE
Mass	211 g
Body dimensions (L × W × H in mm)	86 × 53.3 × 33 (including connectors)
Regulations	CE, RoHS, REACH, WEEE, FCC, ICES

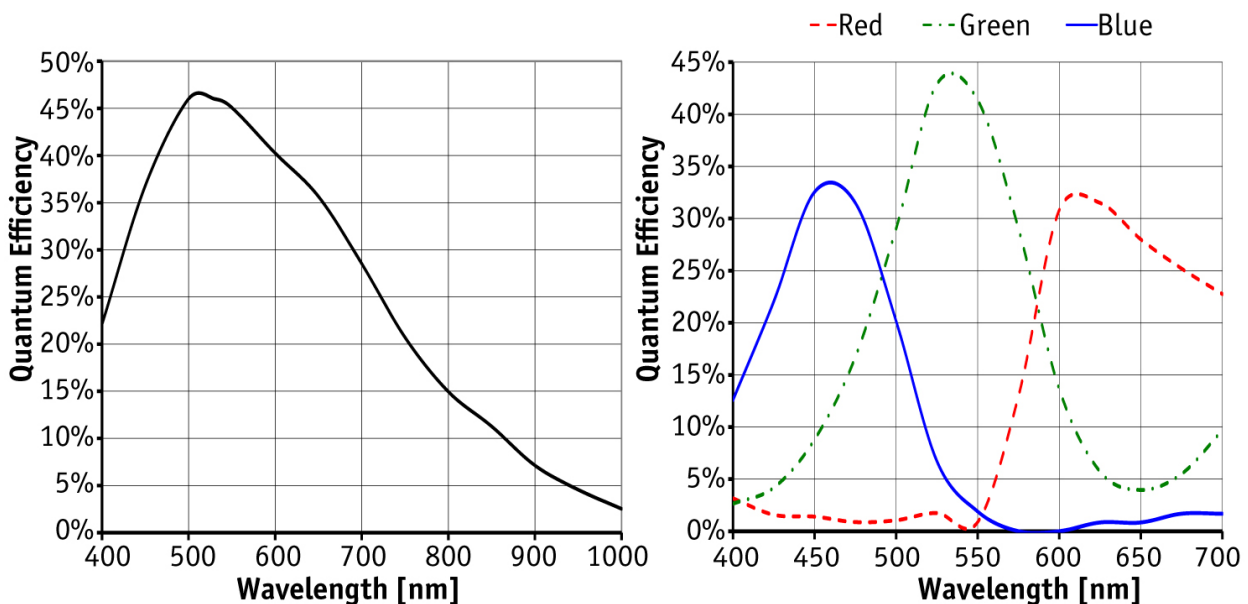

## Features

### Image optimization features:

- Auto gain (manual gain control: 0 to 30#dB)
- Auto exposure (manual exposure control:#25 #s to 42.9 s)



- Auto white balance
- Binning (horizontal and vertical)
- Color correction, hue, saturation
- Decimation X/Y
- Gamma
- Look-up tables (LUTs)
- Region of interest (ROI), separate ROI for auto features
- Reverse X

**Camera control features:**

- P-Iris and DC-Iris lens control
- Event channel
- Image chunk data
- IEEE 1588 precision time protocol (PTP)
- RS232
- Storable user sets
- StreamBytesPerSecond (easy bandwidth control)
- StreamHold
- Sync out modes: Trigger ready, input, exposing, readout, imaging, strobe, GPO#
- Temperature monitoring (main board and sensor board)

## Technical drawing

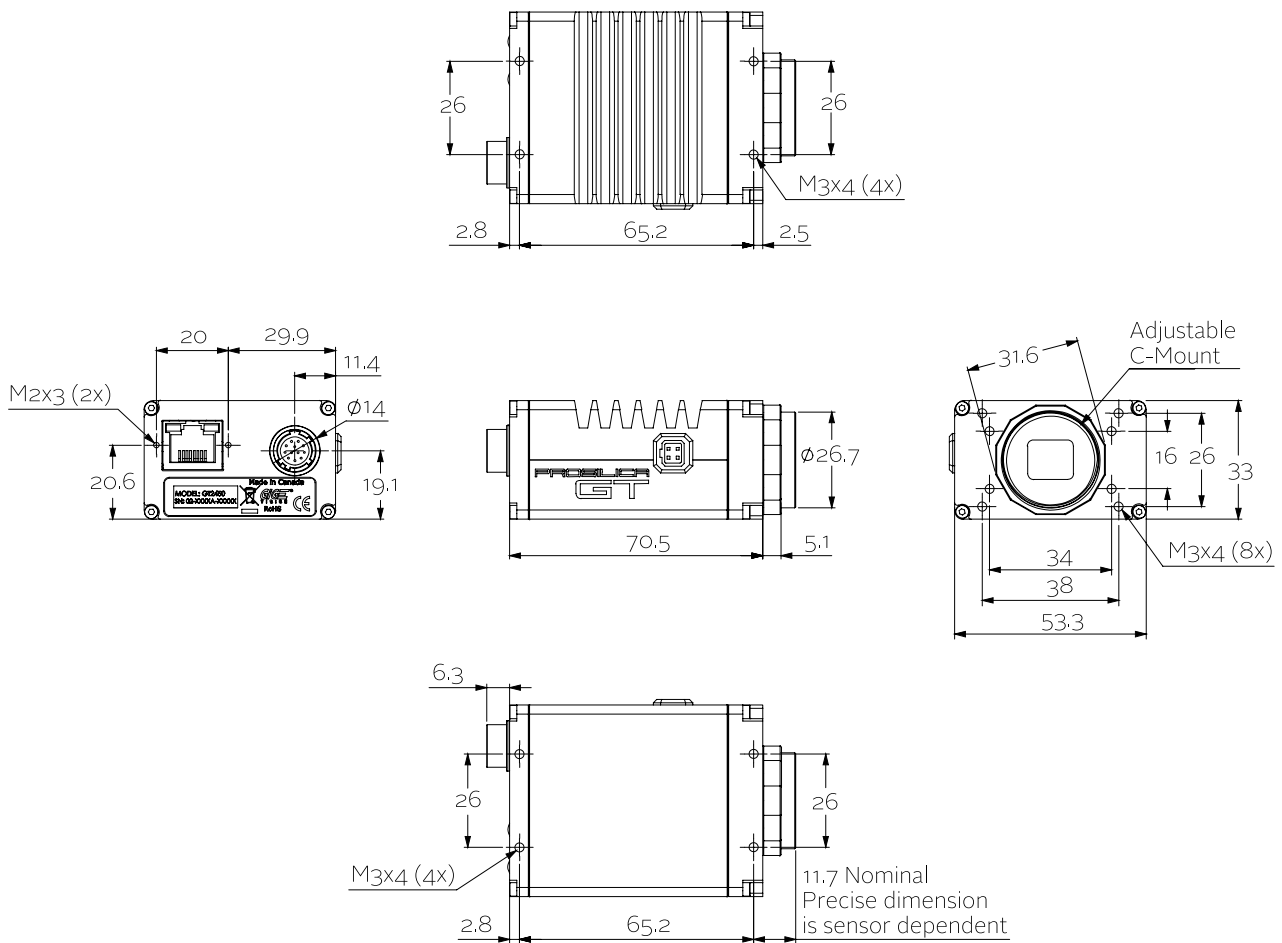

## Applications

Prosilica GT2450/GT2450C is ideal for a wide range of applications including:



- Outdoor imaging
- Traffic imaging / Intelligent Traffic Systems (ITS)
- Public security and surveillance
- Industrial inspection
- Machine vision
- Military and space applications